

ATN PS28

NIGHT VISION CLIP-ON



ATN PS28 OPERATOR'S MANUAL (REV. 3, OCTOBER 2014)

operator's manual

Important Export Restrictions! Commodities, products, technologies and services contained in this manual are subject to one or more of the export control laws and regulations of the U.S. Government and they fall under the control jurisdiction of either the US Department of State or the US BIS-Department of Commerce. It is unlawful and strictly prohibited to export, or attempt to export or otherwise transfer or sell any hardware or technical data or furnish any service to any foreign person, whether abroad or in the United States, for which a license or written approval of the U.S. Government is required, without first obtaining the required license or written approval from the Department of the U.S. Government having jurisdiction. Diversion contrary to U.S. law is prohibited.



**AMERICAN
TECHNOLOGIES
NETWORK
CORP.**

**Register your product warranty online at
www.atncorp.com/warranty**

The information in this manual is furnished for information use only, is subject to change without notice, cannot be construed as a commitment by ATN Corp. ATN Corp. assumes no responsibility or liability for any errors or inaccuracies that may appear in this book.

© 2014 ATN Corp. All right reserved.

SAFETY SUMMARY

CAUTIONS

- The ATN PS28 is a precision optical instrument and must be handled carefully at all times to prevent damage.
- Do not scratch the external lens surfaces or touch them with your fingers.
- To protect the image intensifier, keep the lens cap on the objective lens when the sight is not in use or when checked out in daylight conditions.
- The IR illuminator is the light that is invisible to the unaided eye for use during conditions of extreme darkness. However, the light from the illuminator can be detected by others when using night vision devices.
- If you use the rubber eyecaps for a long period of time, you may suffer skin inflammation. If you develop any symptoms, consult a doctor immediately.

WARNING

Do not carry batteries in pockets containing metal objects such as coins, keys, etc. Metal objects can cause the batteries to short circuit and become very hot.

WARNING

Toxic Material

The image intensifier's phosphor screen contains toxic materials.

- If an image intensifier breaks, be extremely careful to avoid inhaling the phosphor screen material. Do not allow the material to come in contact with the mouth or open wounds on the skin.
- If the phosphor screen material contacts your skin, wash it off immediately with soap and water.
- If you inhale/swallow any phosphor screen material, drink a lot of water, induce vomiting, and seek medical attention as soon as possible.

WARNING

Do not use contaminated light suppressor. They must be replaced.

CAUTION:

**THIS PRODUCT CONTAINS NATURAL RUBBER LATEX
WHICH MAY CAUSE ALLERGIC REACTIONS.**

EQUIPMENT LIMITATIONS

To avoid physical and equipment damage when using the ATN PS28, carefully read and understand the following equipment limitations.

- The equipment requires some night light (moonlight, starlight, etc.) to operate. The level of equipment performance depends upon the level of light.
- Night light reduces by passing through the clouds, while operating under trees, at building shadows, etc.
- The equipment is less effective when viewing into shadows and other darkened areas.
- The equipment is less effective when viewing through the rain, fog, sleet, snow or smoke.
- The equipment will not “see” through the dense smoke.

TABLE OF CONTENTS

	pg.
SAFETY SUMMARY	a
SECTION I. INTRODUCTION	1-1
1.1. General	1-2
1.1.1. Scope	1-2
1.1.2. Reports	1-2
1.1.3. Storage	1-2
1.1.4. Warranty	1-3
1.2. Description and Data	1-5
1.2.1. Description	1-5
1.2.2. Standard Components and Optional Equipment	1-8
SECTION II. OPERATING INSTRUCTIONS	2-1
2.1. Installation Procedures	2-2
2.1.1. Battery Installation	2-2
2.1.2. Installation on MIL-STD-1913 Rail	2-2
2.1.3. Attachment to Dayscope Objective Lens	2-4
2.1.4. Long Rail Adapter	2-5
2.1.5. B.A.M. System	2-6
2.1.6. Remote Control	2-8
2.1.7. IR850 Illuminator	2-9
2.1.8. Mounting Examples	2-11
2.2. Operating Procedures	2-11
2.2.1. General	2-11
2.2.2. Controls and Indicators	2-12
2.2.3. Operating Procedures	2-13
2.2.4. Operating with Remote Control	2-14
2.2.5. Operating with IR850 Illuminator	2-14
2.2.6. Preparation for Storage	2-14
SECTION III. MAINTENANCE INSTRUCTIONS	3-1

3.1. Preventive Maintenance Checks and Services (PMCS)	3-2
3.1.1. Preventive Maintenance Checks And Services Table	3-2
3.1.2. Inspection Criteria for Proper Image Intensifier Operation	3-6
3.2. Troubleshooting	3-10
3.2.1. General	3-10
3.2.2. Troubleshooting Procedures	3-10
3.3. Maintenance Procedures	3-11
3.3.1. PS28 Maintenance	3-11
3.3.2. Cleaning Procedures	3-11
Appendix A. How to select Scope Mounting System	A-1
Appendix B. Estimation of Ambient Illumination Level	B-1

SECTION I

INTRODUCTION

1.1 GENERAL INFORMATION

1.1.1. SCOPE

This manual contains instructions for use in operating and maintaining the ATN PS28 Night Vision Front Sights. Throughout this manual, the ATN PS28 will be referred to as the sights or the PS28.

1.1.2. REPORTS

Reports from the user on recommendations for improvements are encouraged. Send reports to the address below.

American Technologies Network Corp.
1341 San Mateo Avenue
South San Francisco, CA 94080
(800) 910-2862
(650) 989-5100
(650) 875-0129 fax
www.atncorp.com
info@atncorp.com

1.1.3. STORAGE

Storage of the PS28 should be done in the factory packing and after a thorough PMCS as outlined in Section IV of this manual. This will ensure the sight remains in mission ready condition during storage. Battery should be stored separately from the sight.

The PS28 should not be placed on the floor, in any area exposed to high temperatures or direct sunlight. Presence of acid and alkaline vapor, as well as of other aggressive admixtures in the air is unacceptable.

1.1.4. WARRANTY

2 YEAR PRODUCT WARRANTY

This product is guaranteed to be free from manufacturing defects in material and workmanship under normal use for a period of 2 (two) years from the date of purchase. In the event a defect that is covered by the foregoing warranty occurs during the applicable period stated above, ATN, at its option, will either repair or replace the product, and such action on the part of ATN shall be the full extent of ATN's liability, and the Customer's sole and exclusive remedy. This warranty does not cover a product (a) used in other than its normal and customary manner; (b) subjected to misuse; (c) subjected to alterations, modifications or repairs by the Customer or by any party other than ATN without prior written consent of ATN; (d) special order or "close-out" merchandise or merchandise sold "as-is" by either ATN or the ATN dealer; or (e) merchandise that has been discontinued by the manufacturer and either parts or replacement units are not available due to reasons beyond the control of ATN. ATN shall not be responsible for any defects or damage that in ATN's opinion is a result from the mishandling, abuse, misuse, improper storage or improper operation, including use in conjunction with equipment which is electrically or mechanically incompatible with or of inferior quality to the product, as well as failure to maintain the environmental conditions specified by the manufacturer. **CUSTOMER IS HEREBY NOTIFIED THAT OPERATION OF THE EQUIPMENT DURING DAYLIGHT HOURS OR UNDER ANY EXCESSIVE LIGHT CONDITIONS MAY PERMANENTLY DAMAGE THE INTERNAL COMPONENTS OF THE UNIT AND SAID DAMAGE WILL NOT BE COVERED UNDER THIS WARRANTY.** This warranty is extended only to the original purchaser. Any breach of this warranty shall be waived unless the customer notifies ATN at the address noted below within the applicable warranty period.

The customer understands and agrees that except for the foregoing warranty, no other warranties written or oral, statutory, expressed or implied, including any implied warranty of merchantability or fitness for a particular purpose, shall apply to the product. All such implied warranties are hereby and expressly disclaimed.

LIMITATION OF LIABILITY

ATN will not be liable for any claims, actions, suits, proceedings, costs, expenses, damages or liabilities arising out of the use of this product. Operation and use of the product are the sole responsibility of the Customer. ATN's sole undertaking is limited to providing the products and services outlined herein in accordance with the terms and conditions of this Agreement. The provision of products sold and services performed by ATN to the Customer shall not be interpreted, construed, or regarded, either expressly or implied, as being for the benefit of or creating

any obligation toward any third party of legal entity outside ATN and the Customer; ATN's obligations under this Agreement extend solely to the Customer.

ATN's liability hereunder for damages, regardless of the form or action, shall not exceed the fees or other charges paid to ATN by the customer or customer's dealer. ATN shall not, in any event, be liable for special, indirect, incidental, or consequential damages, including, but not limited to, lost income, lost revenue, or lost profit, whether such damages were foreseeable or not at the time of purchase, and whether or not such damages arise out of a breach of warranty, a breach of agreement, negligence, strict liability or any other theory of liability.

PRODUCT WARRANTY REGISTRATION

In order to validate the warranty on your product, ATN must receive a completed Product Warranty Registration Card for each unit or complete warranty registration on our website at www.atncorp.com. Please complete the included form and immediately mail it to our Service Center: ATN Corporation, 1341 San Mateo Avenue, South San Francisco, CA 94080.

OBTAINING WARRANTY SERVICE

To obtain warranty service on your unit, End-user must notify ATN service department by calling 800-910-2862 or 650-989-5100 or via e-mail service@atncorp.com to receive a Return Merchandise Authorization number (RMA).

When returning please take or send the product, postage paid, with a copy of your sales receipt to our service center, ATN Corporation at the address noted above. All merchandise must be fully insured with the correct postage; ATN will not be responsible for improper postage or, missing or damaged merchandise during shipment.

When sending product back, please clearly mark the RMA# on the outside of the shipping box. Please include a letter that indicates your RMA#, Name, Return Address, reason for service return, Contact information such as valid telephone numbers and/or e-mail address and proof of purchases that will help us to establish the valid start date of the warranty. Product merchandise returns that do not have an RMA listed may be refused or a significant delay in processing may occur.

Estimated Warranty service time is 10-20 business days. End-user/customer is responsible for postage to ATN for warranty service. ATN will cover return postage/shipping to continental USA end-users/customers after warranty repair only if product is covered by aforementioned warranty. ATN will return product after warranty service by domestic ground service and/or domestic mail. Any other requested, required or international shipping method the postage/shipping fee will be the responsibility of the end-user/customer.

1.2. DESCRIPTION AND DATA

1.2.1. DESCRIPTION

A. Purpose

The PS28 is an effective night vision system that mounts forward of an existing riflescope/spotting scope (further referred to as a scope) adding night vision capabilities to daytime target acquisition platform. Advisable dayscope magnification is 1X to 12X (2.5X to 8X is optimum). The sight is installed and removed without affecting boresight (permanent boresight alignment).

NOTE

The PS-28 can be installed also forward of viewfinders of various instruments to widen operating illumination range.

B. Principle of Operation

The PS28 operation is based on the principle of electron-optical intensification of light. The input fast catadioptric lens collects available ambient light from sources such as the moon, stars and skylight and focuses it on the image intensifier tube photocathode. The tube amplifies the light and produces the viewable image projected by the output lens from the tube screen into the dayscope lens. Thus the sight provides the capability for operator to see through the scope at night.

C. Features

The PS28 has the following important features:

- Available with 2+, 3, WPT™* or 4th generation image intensifier tube.
- Powered by a single 123A lithium battery.
- Adjusts for lens focus.
- Automatic Brightness Control System always keeps the IIT brightness level constant, even under unsteady brightness conditions.
- Equipped with remote control.

* WPT is a registered trademark of American Technology Network Corp.

- Is mounted on MIL-STD-1913 rail or dayscope lens.
- Is submersible to 10 m for 30 minutes.
- Filled with dry nitrogen to prevent internal fogging.

D. System Limitations

The PS28 is an effective night vision system designed for night operations but does have the following limitations:

- The sight requires some night light (moonlight, starlight, etc.) to operate. Night light is reduced by such factors as passing cloud cover and objects that produce shadows.
- The sight is less effective viewing through rain, fog, sleet, snow, smoke.
- Under starlight conditions low contrast environments (such as snowcovered territory, sandy deserts, large bodies of water or grassy hills) degrade visibility thereby disguising or masking changes in terrain.
- Under low-light conditions the sight loses some of the resolution that it has under full moon.

TABLE 1-1. SYSTEM DATA

ITEM	DATA
Magnification	Unity (1 X)
Boresight Characteristics:	
Accuracy	Factory aligned to ½ MOA or better
Retention	Permanent to within 1 MOA or better
Repeatability	Within ½ MOA
System Resolution subject to Tube Resolution:	
36 to 44 lp/mm	0.38 mrad/lp
45 to 54 lp/mm	0.30 mrad/lp
55 to 64 lp/mm	0.25 mrad/lp
Over 65 lp/mm	0.21 mrad/lp

TABLE 1-2. MECHANICAL DATA

ITEM	DATA
Dimensions (Length x Width x Height)	7.7"x3.5"x3"/ 195x89x76 mm
Weight	1.85 lbs/ 0.84 kg

TABLE 1-3. ELECTRICAL DATA

ITEM	DATA
Battery	CR123A (3 V)
Consumption Current: at 3.0 V	38 mA
Cell Life at 20°C: 123A Lithium Battery	36 hours

TABLE 1-4. OPTICAL DATA

ITEM	DATA
Objective Lens Focal Length	80 mm
Objective Lens F/number	1:1.10
Focus Range	10 m to infinity
Field of View	15°
Output Lens Exit Pupil Diameter	40 mm

TABLE 1-5. ENVIRONMENTAL DATA

ITEM	DATA
Operating Temperature	-40 to +50°C
Storage Temperature	-50 to +50°C
Humidity	95 %, 25°C to 40°C for 48 hours
Illumination Required	Natural night illumination (overcast starlight to moonlight)
Immersion	10 m for 30 minutes

1.2.2. PS28 STANDARD COMPONENTS AND OPTIONAL EQUIPMENT

The PS28 standard components are shown in Figure 1-1 and presented in Table 1-6.

TABLE 1-6. PS28 STANDARD COMPONENTS

ITEM	DESCRIPTION	QTY
1	ATN PS28 Night Vision Front Sight	1
2	Objective Lens Cap	1
3	Quick Release Mount (QRM)	1
4	Light Suppressor	1
5	Remote Control	1
6	IR850-B1 IR Illuminator Kit	1
7	Shipping /Storage Case	1
8	Battery 123A, Lithium	1
9	Operating Manual	1

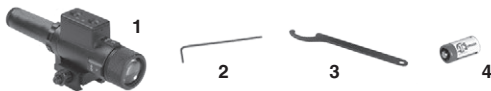

FIGURE 1-1. PS28 STANDARD COMPONENTS

IR850-B1 IR Illuminator Kit is shown in Figure 1-2 and listed in Table 1-7.

TABLE 1-7. IR850-B1 IR ILLUMINATOR KIT

ITEM	DESCRIPTION	QTY
1	IR850-B1	1
2	1,5 mm Allen Key	1
3	IR850 Wrench	1
4	Battery 123A, Lithium	1

**FIGURE 1-2. IR850-B1 IR ILLUMINATOR KIT**

Optional items are shown in Figure 1-3 and listed in Table 1-8.

TABLE 1-8. PS28 OPTIONAL EQUIPMENT

ITEM	DESCRIPTION	PART CODE
1	Weaver Mount	ACDNPS40MWVR
2	Scope Mounting System #1	ACDNPS40SM01
3	Scope Mounting System #2	ACDNPS40SM02
4	Boresight Attachment Mount (B.A.M.)	ACDNPS40BM01
5	Long Rail Adapter	ACWSLRADPT
6	Platform Ring	ACWSRTRA

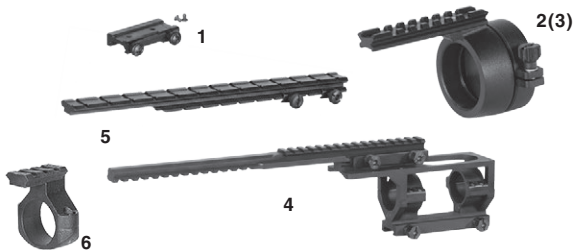

FIGURE 1-3. PS28 OPTIONAL EQUIPMENT

SECTION II

OPERATING INSTRUCTIONS

2.1. INSTALLATION PROCEDURES

2.1.1. BATTERY INSTALLATION

CAUTION

Ensure the function switch is in the off position before installing a battery.

Install the battery as follows:

1. Unscrew the battery compartment cap.
3. Install the battery into the battery compartment as shown. Follow battery symbol on the sight body (Figure 2-1).
5. Replace the battery compartment cap.

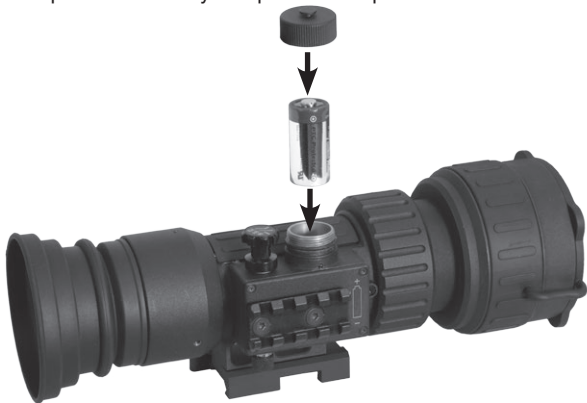

**FIGURE 2-1.
BATTERY INSTALLATION**

2.1.2. INSTALLATION ON MIL-STD-1913 RAIL

Quick Release Mount (QRM) is used for fast installation/removing the PS28 on MIL-STD-1913/Picatinny rail.

NOTE

The optical axis of the PS28 and the riflescope should be matched. Difference of the axes position more than 3 mm is not recommended. Measure the height of the riflescope axis above the rail. Observe Table 1-2 for the sight axis height above the rail. If the difference in the axis heights of the PS28 and riflescope is more than 3 mm it is necessary to replace riflescope mounting rings or monoblock by proper ones.

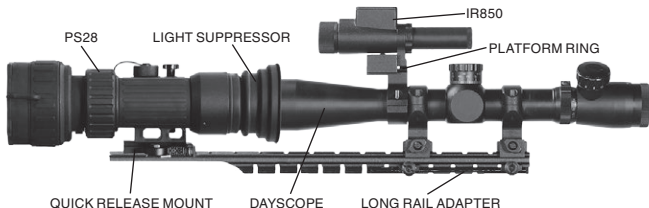

FIGURE 2-2. PS-28 INSTALLED ON MIL-STD-1913 RAIL FORWARD OF DAYSCOPE

Slide the locking button of mount lever forward (Figure 2-3, arrow A). Turn the mount lever backwards to open the mount (Figure 2-3, arrow B).

2. Install the sight forward the riflescope on the arm rail as close to the riflescope as possible. The light suppressor should cover the riflescope objective lens.
3. Turn the lever forwards pushing and sliding forward locking button to close the mount.

QR Mount comes factory set to securely fit most standard MIL-STD-1913/Picatinny mounts. However, there may be some slight differences in each mount from various manufacturers. You can loosen or tighten the QRM on your rail by using a 3/8" wrench and adjust the Mount Tightness Nut.

NOTE

If using weaver rails, please consult your gunsmith for modification to rail.



FIGURE 2-3. QUICK RELEASE MOUNT

2.1.3. ATTACHMENT TO DAYSCOPE OBJECTIVE

Scope mounting systems are designed to install the PS28 on rifle-scope/sporting scope objective lens.

CAUTION

The PS28 can not be attached to the riflescope/sporting scope that have a focusing ring on the objective lens housing.

The scope mounting systems and inserts differ in attaching diameters and are supplied on special order, taking into account the parameters of the scope.

NOTE

Optical axes of the PS28 and the riflescope should be matched. Difference of the axes position more than 3 mm is not recommended.

Install the PS28 on dayscope objective lens as follows:

1. Loosen and remove two mounting screws M4x8 the Quick Release Mount, remove the mount and put it into the storage case.
2. Take off the output lens cap and put it into the storage case.

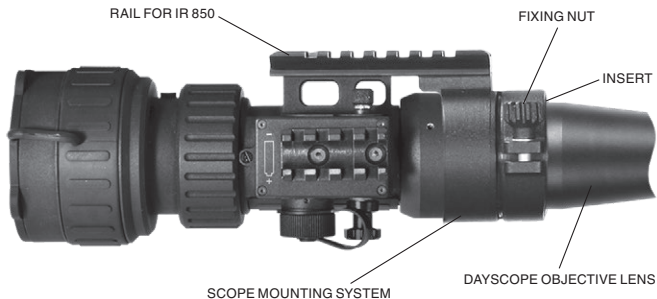

FIGURE 2-4. PS28 INSTALLED ON DAYSCOPE OBJECTIVE LENS

3. Insert the output lens into the scope mounting system and place the rail of the mounting system where the Quick Release Mount was above the battery compartment of the sight.
4. Apply a small amount of thread locker on threads, install two screws M4x8 and tighten it.
5. Loosen the nut of the mounting system.
6. Slide the PS28 with mounting system onto the objective lens of dayscope up to the stop.
7. To complete the installation of the mounting system to your day-scope, use a screw driver to tighten the nut of the mounting system. Do not apply excessive torque.

2.1.4. LONG RAIL ADAPTER

Optional Long Rail Adapter (LRA) can be used if the firearm has a short scope mounting rail which prevents the installation of the PS28 forward of dayscope.

Install the PS28 with LRA as follows (Figure 2-5):

1. Slightly loosen the two fixing screws (1) on the LRA (2).
2. Place the LRA on the mount of the fire arm (3).
3. Tighten the fixing screws of LRA.
4. Install the daytime scope (4) onto the LRA.

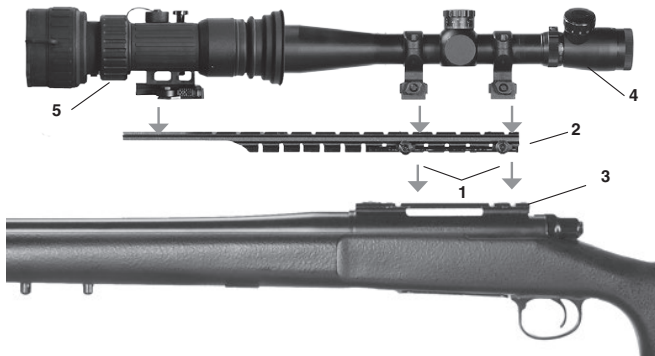

FIGURE 2-5. LONG RAIL ADAPTER INSTALLATION

5. Place the PS28 (5) onto the LRA at front of the scope. The light suppressor of the front sight should cover the riflescope objective lens.

2.1.5. B.A.M. SYSTEM

B.A.M. system (Boresight Attachment Mount) is used to install the PS28 Night Vision Front Sights and the dayscope on the rifles having short mounting MIL-STD-1913 rail.

There are three advantages of the system:

- Low position of the sight and dayscope (36 mm above the rail).
- Incline of the axis of the dayscope and the sight on 20 angular minutes for long range firing.
- Resistance on the rifle with vigorous recoil.

B.A.M. System Installation:

1. Unscrew four screws (10) and replace the top of the mount (9).
2. Install the halves of inserts (4) in the rings on the base.
3. Cradle the scope (5) in the rings (inserts).

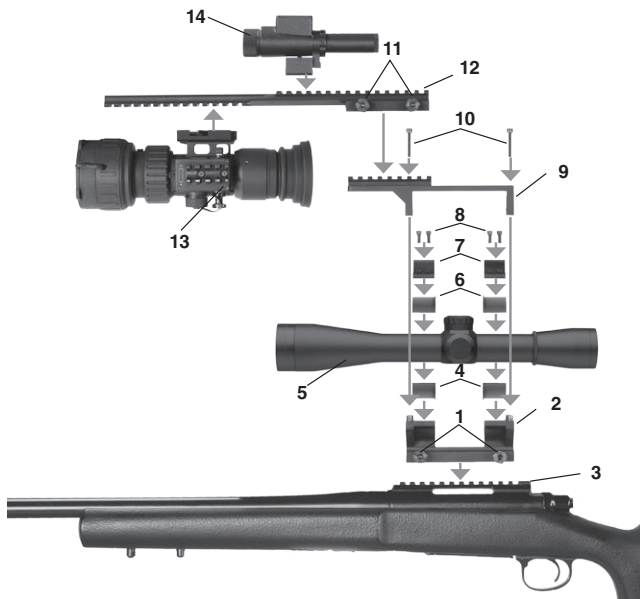

FIGURE 2-6. INSTALLATION OF B.A.M. SYSTEM

4. Install the top halves of the inserts (6) and the rings (7) and tighten each ring's four screws (8) slightly.
5. Slightly loosen the two fixing screws (1) on the mount base (2).
6. Place the base on the mount of the fire arm (3).
7. Tighten the fixing screws of mount base.
8. Adjust lengthwise position of the daytime scope by changing the position of mount base along the weapon mount and moving of scope along the B.A.M. Adjust the position of reticle by rotation of scope in the mounting rings.
9. Tighten four screws (8) tightly.

10. Install the top of the mount (9) and tighten four screws (10) to finger tight.
11. Slightly loosen the two fixing screws (11) on the top rail (12).
12. Place the top rail onto the Picatinny rail on the top of the mount.
13. Tighten the fixing screws of the top rail.
14. Place the Night Vision Front Sight (13) onto the top rail at front of the scope. The light suppressor of the front sight should cover the riflescope objective lens.
15. Place the infra-red illuminator (14) atop of the top rail.

NOTE

There are two sets of inserts for scopes with 25.4 mm and 30 mm tubes diameter.

You can quickly change your system back from night vision to day. Simply unscrew two fixing screws of the top rail and take off the top rail together with the front sight and IR illuminator.

NOTE

The fixing screws may need to be tightened after continuous shooting.

2.1.6. REMOTE CONTROL

Remote control is designed to operate the PS28 in short-time activation mode.

Attach the remote control to the PS28 and use it as follows:

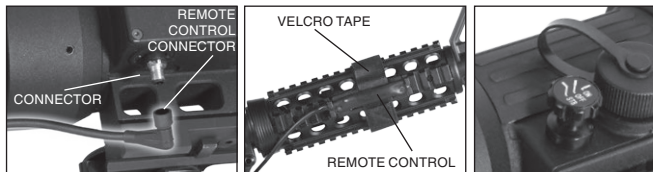

FIGURE 2-7. REMOTE CONTROL

1. Remove the rubber cap from the connector. The rubber cap can be placed onto the screw head, that attached the strap of cap to the body of device (see Figure 2-7).
2. Attach the remote control to the connector and secure with the captive nut.
3. Place the remote switch on the fore-end of rifle stock and with Velcro tape.

2.1.7. IR850 ILLUMINATOR

IR850-B1 illuminator provides the capability for operator to use the PS28 under extremely low light conditions and in total darkness. The IR illuminator can be mounted on rail of the Platform Ring, or on top rail of the B.A.M. system (see Figure 2-6), or of the Scope Mounting System.

IR850 Installation:

1. Loosen the fixing nut of IR850.
2. Install the IR850 onto the Picatinny rail.
3. Tighten the fixing nut of IR850 tightly.

The ATN IR850 is powered with one CR123A lithium battery.

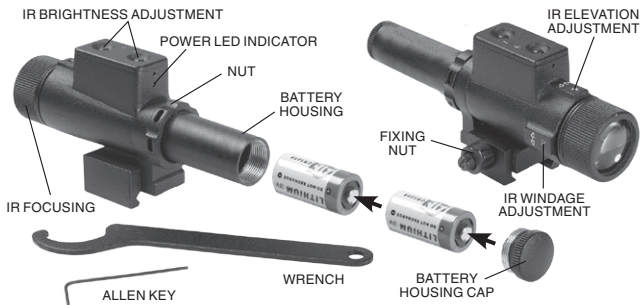

FIGURE 2-8. IR850-B1

To install the battery unscrew the cap of the battery housing and insert the battery following the polarity arrows marked on the housing. Put the cap in place.

The IR-850 illuminator has a control panel with two buttons. To switch the IR illuminator on/off press “+” and “-” buttons simultaneously. When the IR illuminator is switched on you can see the green LED lit on the back side of IR850. By pushing the buttons “+” and “-” you may adjust the IR brightness.

The IR beam is focusable to change the field of coverage. To change the beam width slightly turn the IR lens.

You may need adjust the focusing of the IR beam to change the field of coverage.

Do it by slightly rotating the IR lens. The windage and elevation screws help adjust the direction of the IR beam from the IR850 in order to focus on the scene observed in the viewfinder of your NVD. Use the included Allen wrench to rotate the adjusting screws until the IR beam is centered. Please remember the adjustments should be performed under night light conditions only.

You can change the position of the IR control panel to meet your your needs. The wrench that is included in the set, is used to loosen the nut located on the body of the IR. Rotate the IR to the desired position. Tighten the nut with the wrench to secure the new position.

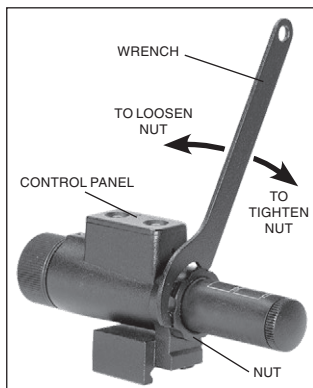

FIGURE 2-9. CHANGING OF CONTROL PANEL POSITION

2.1.8. MOUNTING EXAMPLES



PS28 WITH TRIJICON ACOG



PS28 WITH LEUPOLD DAYTIME SCOPE WITH B.A.M. SYSTEM AND IR850



PS28 WITH LEUPOLD DAYTIME SCOPE WITH SCOPE MOUNTING SYSTEM

FIGURE 2-10. PS28 MOUNTING EXAMPLES

2.2. OPERATING PROCEDURES

2.2.1. GENERAL

This section contains instructions for placing the PS-28 into operation. The function of controls is explained.

CAUTION

The PS28 is a precision electro-optical instrument and must be handled carefully at all times.

2.2.2. CONTROLS AND INDICATORS

LEFT SIDE VIEW



REMOTE CONTROL

RIGHT SIDE VIEW

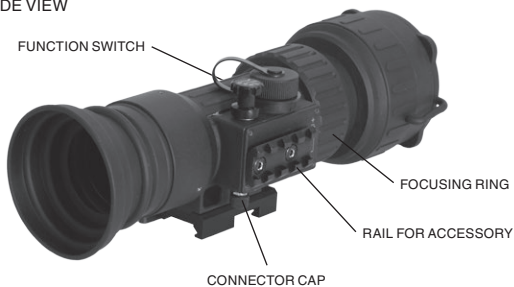

FIGURE 2-11. PS28 CONTROLS AND INDICATORS

TABLE 2-1. PS28 CONTROLS AND INDICATORS

CONTROLS	FUNCTION
Function Switch	OFF — the sight is off.
	STB — the sight is in standby mode.
	ON — the sight is on. Switch's spring is loaded.
Focusing Ring	Focuses the input lens. Adjusts for sharpest view of scene.
Remote control	Switches the sight from STB to operating mode.

2.2.3. OPERATING PROCEDURES

These procedures should be performed under night light conditions only.

CAUTION

Use of the PS28 under high light conditions may damage the image intensifier.

1. Make sure the battery is installed as indicated on the sight body.
2. Make visual estimation of the illumination level in the viewing area is less than 1 lux (late twilight sky conditions).
3. Remove the front lens cap and place it over the lens housing.

CAUTION

Ensure the light sensor is open before removing the objective lens cap.

4. Turn the power switch to the ON position. A green glow will appear in the scope eyepiece (after a slight delay).
5. Observe the scene and adjust focus rotating focusing knob to achieve sharp image.

CAUTION

Bright sources such as light of fire, headlights, searchlights, etc. can damage the PS28. Avoid exposing the PS28 to these types light sources.

6. If the day-time scope has focusing rings (parallax adjustment knob), adjust focus for parallax free image.
7. If the day-time scope has reticle illumination, switch it on and adjust reticle brightness.
8. PS28 Shut-Down:
 - a) Turn the function switch to OFF position. The green of the image intensifier tube glow will fade to black.
 - b) Replace the protective cover on the input lens.
 - c) If necessary remove the sight from the rail (from the scope lens) remove the sight in reverse order of the installation instructions.
 - d) Unscrew the battery cap and take out the battery. Replace the battery cap. Do not store the PS28 with the battery still in it.
 - e) Return the sight and all accessories to the case.

2.2.4. OPERATING WITH REMOTE CONTROL

1. Turn the function switch in standby position (STB).
2. To activate the sight, press and hold the pressure switch.
3. After disconnecting the remote control, replace the cap onto the connector.

2.2.5. OPERATING WITH IR850 ILLUMINATOR

Infra-red (IR) Illuminators are common for night vision technology. The IR light greatly enhances the performance of your device, while remaining almost totally invisible to the naked eye. Staying in the dark, switch on your night vision device. If the visibility is low, you may use ATN IR850 to improve the situation. Still, you should remember that the IR illuminator is just a source of infrared light so the greater is the chosen range of observation, the lesser its brightness becomes.

2.2.6. PREPARATION FOR STORAGE

- (1) Shutdown. Perform the following procedures to shut down the sight.

- (a) Turn the sight function switch to the OFF position.
- (b) Remove the sight from the weapon or daytime riflescope.
- (c) Remove attached accessories.

WARNING

Do not carry batteries in pockets containing metal objects such as coins, keys, etc. Metal objects can cause the batteries to short circuit and become very hot.

(2) Packaging After Use.

- (a) Remove batteries.
- (b) Inspect the battery housing for corrosion or moisture.
Clean and dry if necessary.
- (c) Install objective lens cap.

NOTE

• Prior to placing MUNVM into storage case, ensure MUNVM and case are free of dirt, dust, and moisture.

- (d) Place the sight into the storage case, close and latch.
- (e) Return to storage area.

SECTION III

MAINTENANCE INSTRUCTIONS

3.1. PREVENTIVE MAINTENANCE CHECKS AND SERVICES (PMCS)

3.1.1. PREVENTIVE MAINTENANCE CHECKS AND SERVICES TABLE

A. General

To ensure the readiness of the NVFS, perform the preventive maintenance procedures in accordance with Table 2.2., prior to each mission. Preventive maintenance procedures include inspection, cleaning, and performance of the checkout procedures.

B. Warnings and Cautions

Always observe the WARNINGS and CAUTIONS appearing in the table. Warnings and cautions appear before applicable procedures. You must observe the warnings and cautions to prevent serious injury to yourself and others, or to prevent your equipment from being damaged.

C. Explanation of Table Entries

(1) Item Number Column. Numbers in this column are for reference. When completing Equipment Inspection and Maintenance Worksheet, include the item number for the check/service indicating a fault. Item numbers also appear in the order that you must do checks and services for the intervals listed.

(2) Interval Column. This column tells you when you must do the procedure in the procedure column. BEFORE procedures must be done before you operate or use the equipment for its intended mission. DURING procedures must be done during the time you are operating or using the equipment for its intended mission. AFTER procedures must be done immediately after you have operated or used the equipment.

(3) Location, Check/Service Column. This column provides the location and the item to be checked or serviced. The item location is underlined.

(4) Procedure Column. This column gives the procedure you must do to check or service the item listed in the Check/Service column to know if the equipment is ready or available for its in-

tended mission or operation. You must do the procedure at the time stated in the interval column.

(5) Not Fully Mission Capable If: Column. Information in this column tells you what faults will keep your equipment from being capable of performing its primary mission. If you make check and service procedures that show faults listed in this column, do not operate the equipment. Follow standard operating procedures for maintaining the equipment or reporting equipment failure.

NOTE

Damaged accessory items (sacrificial window, demist shield, compass) do not cause the entire end item to be “not fully mission capable”. However, the damaged item should be replaced as soon as practical to restore full capability of the system.

D. Other Table Entries

Be sure to observe all special information and notes that appear in your table.

**TABLE 3.1. PREVENTIVE MAINTENANCE CHECKS
AND SERVICES FOR THE PS28.**

ITEM NO.	INTER-VAL	LOCATION CHECK/SERVICE	PROCEDURE	NOT FULLY MISSION CAPABLE IF:
1	Before	Completeness	Open carrying case and check the inventory items	Items missing
<u>SIGHT</u>				
2	Before/After	Sight Body	Inspect for missing screws or connector cap.	Screws or connector cap missing.
3	Before/After	Front Lens Cap	Inspect for cuts, tears and dirt. Clean as required.	Cap torn or cut.
4	Before/After	Battery Compartment	Check for corrosion, thread damage or dirt, cap and battery adapter damaged or missing. Check O-ring for cuts or damage.	Cap, adapter or O-ring damaged or missing.
5	Before/After	Function Switch	Check for operation (without battery).	Switch inoperative. Switch missing.

ITEM NO.	INTERVAL	LOCATION CHECK/SERVICE	PROCEDURE	NOT FULLY MISSION CAPABLE IF:
6.	Before/After	Lenses	Inspect for cleanliness, scratches, chips or cracks. Clean as required.	Chipped, cracked or if scratches hinder vision through the sight
7	Before/After	Objective Lens	Check to ensure the objective lens is not loose.	Objective lens loose.
ACCESSORIES				
8	Before/After	Remote Control	Check cable and key for damage. Check Velcro tape for wear. Ensure the remote control connects to the sight plug securely.	Cable or key damaged. Velcro tape missing. Connector damage affects ability to connect remote control to the sight.
9	Before/After	Light Suppressors	Inspect for cuts, tears or thread damage. Check ease of installation and removal.	Thread damage hinder installation. Suppressors torn or cut.
10	Before/After	QRM	Check for damage, dust, dirt or corrosion.	Damaged, will not mount to rail.
11	Before/After	Picatinny Rail	Check for damage, dust, dirt or corrosion.	Damaged, will not mount to NVFS.
12	Before/After	Platform Ring	Check for damage, dust, dirt or corrosion.	Damaged, will not mount to day scope.
13	Before/After	Long Rail Adapter	Check for damage, dust, dirt or corrosion.	Damaged, will not mount to rail.
14	Before/After	B.A.M.	Check for damage, dust, dirt or corrosion.	Damaged, will not mount.
15	Before/After	Scope mounting system	Check for damage, dust, dirt or corrosion.	Thread or body damage hinder installation. Ring loosed. Insert or nut missing.
16	Before/After	Storage Case	Remove all items and shake out loose dirt or foreign material. Inspect for tears, cuts, excess wear, or damage to mounting clips.	Damaged, will not latch securely.

ITEM NO.	INTER-VAL	LOCATION CHECK/SERVICE	PROCEDURE	NOT FULLY MISSION CAPABLE IF:
NOTE If any of the following items are damaged it does not cause the entire end item to be "not fully mission capable". However, the damaged item should be replaced as soon as practical to restore full capability of the system.				
<u>OPERATIONAL CHECKS</u>				
CAUTION Operate the PS28 with Front Lens Cap on or under dark conditions.				
17	Before/After	Installation security	Check the sight which installed on the rail or day-scope lens does not have any movement. Tighten fixing nuts if necessary.	
18	Before/After	Function Switch	Insert the battery. Turn the switch to ON position. Look for green glow in output lens. Turn the switch to OFF position.	Green glow absent.
19	Before/After	Remote control	Connect the remote control to the sight. Turn the function switch to STB position. Press and hold the key. Look for green glow in output lens. Release the key; turn the switch to OFF position.	Green glow absent.
20	Before/After	Viewed Image	Refer to paragraph 2.4. to inspect for operational defects.	Flickering, flashing, edge glow, or shading is observed.
<u>AFTER CHECKING PROCEDURES</u>				
21	Before/After		Replace protective covers on the lenses. Disconnect the remote control and screw up the cap. Remove the battery. Return the sight and all accessories to the storage case.	

3.1.2. INSPECTION CRITERIA FOR PROPER IMAGE INTENSIFIER OPERATION

A. General

As directed in the Preventive Maintenance Checks and Services table, image intensifier operation must be checked before each mission. This section provides information for the operator concerning what to look for, how to look for it, and how to determine if the NVFS should be returned to the maintainer.

CAUTION

Perform the following inspection in the dark.

To perform this inspection, attach the sight to the daytime scope as described in paragraph 2.1.3. and turn the function switch to the ON position. Look through the monocular and view the image.

There are two groups of “defects” you may encounter – operational defects and cosmetic blemishes. Operational defects are an immediate cause to reject the NVFS. Cosmetic blemishes are not a cause for rejection unless they become severe enough to interfere with the ability to perform the mission. **The rejection of any NVFS for cosmetic defects must be based on an outdoor evaluation and not the TS-4348/UV Test Set.**

B. Operational Defects

These defects relate to the reliability of the image intensifier and are an indication of instability. If identified, they are an immediate cause for rejecting the NVFS. They include shading, edge glow, flashing, flickering, and intermittent operation.

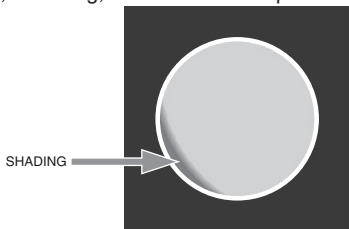

FIGURE 3-1. SHADING

(1) Shading. If shading is present, you will not see a fully circular image (see Figure 3.1). Shading is very dark and you cannot see an image through it. Shading always begins on the edge and migrates inward eventually across the entire image area. Shading is a high contrast area with a distinct line of demarcation. Return the NVFS to the maintainer.

(2) Edge Glow. Edge glow is a bright area (sometimes sparkling) in the outer portion of the viewing area (see Figure 3-2).

To check for edge glow, block out all light by cupping a hand over the objective lens. If the image intensifier is displaying edge glow the bright area will still show up. Return the NVFS to the maintainer.

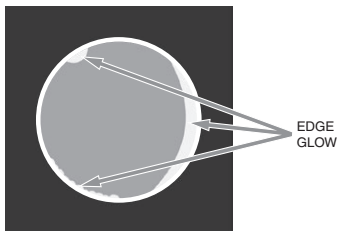

FIGURE 3-2. EDGE GLOW

(3) Flashing, Flickering, or Intermittent Operation. The image may appear to flicker or flash. If there is more than one flicker, check for loose battery cartridge or weak batteries. If weak or loose batteries are not the problem return the NVFS to the maintainer.

C. Cosmetic Blemishes

These are usually the result of manufacturing imperfections that do not affect intensifier reliability and are not normally a cause for rejecting an NVFS. However, some types of blemishes can get worse over time and interfere with the ability to perform the mission. If you believe a blemish is cause for rejection, record the specific nature of the problem on the maintenance forms and identify the position of the blemish by using the clock method and approximate distance from the center (e.g., 5 o'clock toward the

outside, 2:30 near the center, or 1:00 midway). The following are cosmetic blemishes:

(1) Bright Spots. A bright spot is a small, nonuniform, bright area that may flicker or appear constant (Figure 3-3). Not all bright spots make the NVFS rejectable. Cup your hand over the objective lens to block out all light. If the bright spot remains, return the NVFS to the maintainer. Bright spots usually go away when the light is blocked out. Make sure any bright spot is not simply a bright area in the scene you are viewing. **Bright spots are acceptable if they do not interfere with the operator's ability to view the image or to perform the mission.**

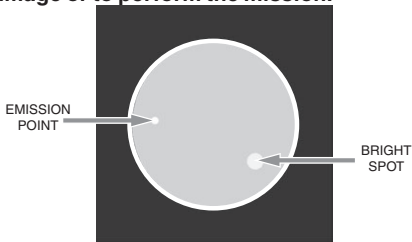

FIGURE 3-3. BRIGHT SPOTS AND EMISSION POINTS

(2) Emission Points. A steady or fluctuating pinpoint of bright light in image area that does not go away when all light is blocked from the objective lens of the monocular (Figure 2.5.). The position of an emission point within the image area does not move.

Not all emission points make the NVFS rejectable. Make sure any emission point is not simply a point light source in the scene you are viewing. **Emission points are acceptable if they do not interfere with the operator's ability to view the image or to perform the mission.**

(3) Black Spots. These are cosmetic blemishes in the image intensifier or dirt or debris between the lenses. Black spots are acceptable as long as they do not interfere with viewing the image. **No action is required if this condition is present unless the spots interfere with the operator's ability to view the image or to perform the mission.**

(4) Fixed-Pattern Noise. This is usually a cosmetic blemish characterized by a faint hexagonal (honeycomb) pattern throughout the viewing area that most often occurs at high light levels or when viewing very bright lights (see Figure 3-4). This pattern can be seen in every image intensifier if the light level is high enough. **This condition is acceptable as long as the pattern does not interfere with the operator's ability to view the image or to perform the mission.**

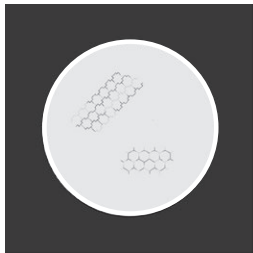

FIGURE 3.4. FIXED-PATTERN NOISE

(5) Chicken Wire. An irregular pattern of dark thin lines in the field-of-view either throughout the image or in parts of the image area (see Figure 3-5). Under the worst case condition, these lines will form hexagonal or square-wave shaped lines. **No action is required if this condition is present unless it interferes with the operator's ability to view the image or to perform the mission.**

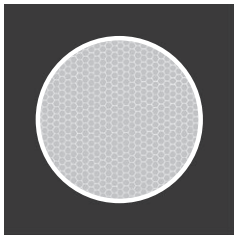

FIGURE 3.5. CHICKEN WIRE

3.2. TROUBLESHOOTING

3.2.1. GENERAL

This section contains information for locating and removal most of the PS28 operating troubles which may occur. Each malfunction for an individual component or assembly is followed by a list of tests or inspections that will help determine probable causes and corrective action to take. Perform the tests/ inspections and corrective actions in the order listed.

This manual cannot list all possible malfunctions that may occur, or all tests or inspections and corrective actions. If a malfunction is not listed (except when malfunction and cause are obvious), or is not corrected by listed corrective actions, contact to the service center.

3.2.2. TROUBLESHOOTING PROCEDURES

Troubleshooting procedures are listed in Table 3-2.

TABLE 3-2. TROUBLESHOOTING PROCEDURES

PROBLEM	PROBABLE CAUSE	CORRECTIVE ACTION
Sight will not come on.	Battery is missing or improperly installed.	Insert battery or install correctly.
	Battery is dead.	Replace battery.
	Battery contact surfaces or contact springs dirty or corroded.	Clean the contact surfaces with a pencil eraser and/or alcohol and cotton swabs.
	Defective image tube.	Send the sight to the service center.
Cannot achieve the sharp image of the object.	Objective and output lenses dirty.	Clean thoroughly the lenses surfaces.
Sight affects boresight after installation or during the firing.	Objective lens loose.	Screw objective lens up to the stop. Apply a small amount of thread locker on threads, install three screws M2.5x3 and tighten.
	Factory alignment broken.	Send the sight to the service center.

3.3. MAINTENANCE PROCEDURES

3.3.1. PS28 MAINTENANCE

The PS28 maintenance consists of external inspection of its components for serviceability, cleaning and installation of the standard and optional accessories. Maintenance instructions covered elsewhere in this manual (PMCS, troubleshooting, etc.) are not repeated in this section.

CAUTION

The PS28 is a precision electro-optical instrument and must be handled carefully at all times to prevent damage.

3.3.2. CLEANING PROCEDURES

A. Cleaning of the PS28

1. Gently brush off any dirt from the sight body using only a clean soft cloth.
2. Moisten the cloth with fresh water and gently wipe the external surfaces (except glass surfaces).
3. Dry any wet surfaces (except lenses) with another dry and clean soft cloth.
4. Using lens brush, carefully remove all loose dirt from glass surfaces.
5. Slightly dampen a cotton swab with ethanol and lightly and slowly wipe the lenses and the light sensor. Clean the glass surfaces by circular movements from the centre to the edge, not touching the lens holders and changing cotton swab after each circular stroke. Repeat this step until the glass surfaces are clean.

B. Cleaning of Accessories

Clean accessories with a soft brush (cloth) and soap and water as required.

CAUTION

Dry thoroughly each item before replacing into the storage case.

APPENDIX A

HOW TO SELECT SCOPE MOUNTING SYSTEM REQUIRED FOR YOUR DAYTIME SCOPE

By selecting the appropriate Scope Mounting System (with Inserts) you can mount the PS28 on a daytime scope with an objective tube diameter from 47 to 58,7 mm. At the Table 2-1 Scope Mounting System sizes (#1-2) and Insert sizes for different scope examples are provided.

If your specific daytime scope is not listed in Table 2-1, before mounting procedure you have to select the proper Scope Mounting System (and Insert) required.

To do this, perform the following actions:

1. Determine your daytime scope objective tube diameter (external - not diameter of the glass lens) with a metric ruler (with a tram-mel for more accurate results) as shown in Figure B-1.
2. Select from the Table 2-1 the Insert size closest (larger) to the value measured (Insert size is also specified at an Insert body). Do the selection in Insert group that corresponds to the same Scope Mounting System (for example, Scope Mounting System #2).
3. The Scope Mounting System you need is the one that corresponds to Insert size selected at the Table 2-1.

For example, if your scope objective tube diameter is equal to 56 mm then you should select Insert with size of 56 mm and corresponding Scope Mounting Systems #1 from the Table 2-1.

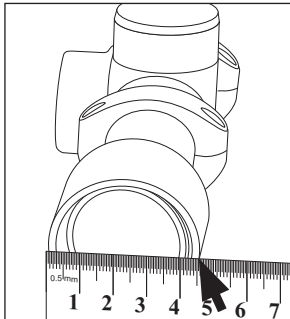

FIGURE B-1.
OBJECTIVE TUBE DIAMETER
MEASURING

APPENDIX B

ESTIMATION OF AMBIENT ILLUMINATION LEVEL

Some of usual natural light conditions and corresponding representative illumination values are presented in Table B-1.

TABLE B-1.

STANDARD NATURAL LIGHT CONDITIONS AND ILLUMINATION VALUES

STANDARD NATURAL LIGHT CONDITIONS	ILLUMINATION VALUE, LUX
Quarter moon	0.05
Full moon	0.30
Late twilight sky	1.00
Twilight sky	10.00
Overcast sky in the daytime	500.00



For customer service and technical support, please contact

American Technologies Network Corp.

1341 San Mateo Avenue, South San Francisco, CA 94080
phone: 800-910-2862, 650-989-5100; fax: 650-875-0129

www.atncorp.com